



**S100**

Loaders



# Specifications

## Machine Rating S100

Rated operating capacity	453 kg
Tipping load	907 kg
Pump capacity	50 l/min
System relief at Quick Couplers	207 bar
Travel speed	10.4 km/h

## Engine

Make / Model	Kubota / V1505-E2B-BCZ-1
Fuel / Cooling	Diesel / Liquid
Maximum power at 3000 RPM (SAE J1349)	25 kW
Torque at 1700 RPM (SAE J1349)	93 Nm
Number of cylinders	4
Displacement	1498 mm
Fuel tank capacity	45 l

## Weights

Operating weight (with std tyres, 48 inch bucket)	1800 kg
Operating weight (with hd tyres, 50 inch bucket)	1818 kg

## Controls

Vehicle steering	Direction and speed controlled by two hand levers
Loader hydraulics tilt and lift	Separate foot pedals
Front auxiliary (standard)	Lateral movement of right-hand steering lever

## Drive System

Transmission	Infinitely variable tandem hydrostatic piston pumps, driving two fully reversing hydrostatic motors
--------------	---

## Standard Features

Automatically activated glow plugs	Operator cab Deluxe *†
High-back cushion suspension seat	Parking brake
Bob-Tach™ frame	Seat belt
Engine / Hydraulic system shutdown	Seat bar
Bobcat Interlock Control System (BICS)	Spark arrestor muffler
Operating lights, front and rear	Heavy-duty tyres — 27 x 8.50-15 6-ply
Instrumentation	Bobcat Heavy Duty
Lift arm support	CE certification

\* Roll Over Protective Structure (ROPS) – meets requirements of SAE-J1040 and ISO 3471; Falling Object Protective Structure (FOPS) – meets requirements of SAE-J1043 and ISO 3449, Level I

† Cab Deluxe includes Interior cab foam, top and rear windows, deluxe wire harness, domelight and electrical power port

## Options

Heated enclosed cab
Power Bob-Tach™
Hydraulic bucket positioning (including ON/OFF switch)
Counterweights

## Attachments

Angle blade (snow blade)	Pallet forks
Angle broom*†	Scraper
Auger	Snow blower*
Buckets (GP 50" and 56")	Soil conditioner*
Cutter crusher*	Sweeper
Digger	Three-point hitch
Dumping hopper	Tiller
Front scarifier	Tilt-Tach
Grapples and forks	Tree fork
Hydraulic breaker**	Trencher
Landplane	
Loader X-Change™ frame (for breaker)	

\*Attachment control kit required.

\*\*When operating the loader with this attachment, a Special Applications Kit, which includes a 12 mm Lexan front door with 6 mm top and rear windows, must be used.

†Optional water kit.

## Dimensions

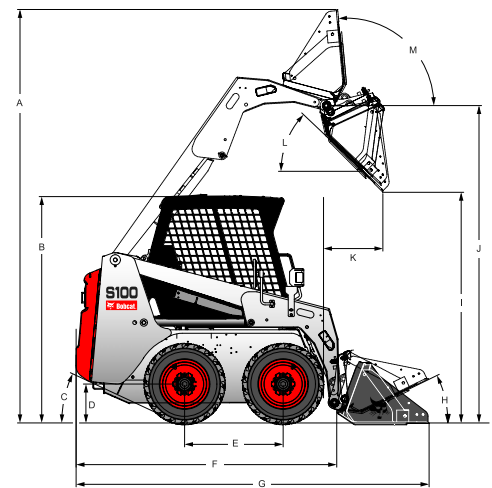

- (A) 3430 mm
- (B) 1878 mm
- (C) 25°
- (D) 167 mm
- (E) 818 mm
- (F) 2262 mm
- (G) 2929 mm
- (H) 26°
- (I) 1971 mm
- (J) 2633 mm
- (K) 477 mm
- (L) 43.4°
- (M) 95°
- (N) 1267 mm
- (O) 1819 mm
- (P) 967 mm
- (Q) 1182 mm

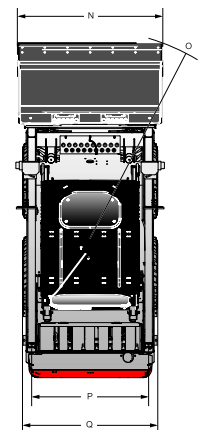

**Bobcat Europe**  
Drève Richelle 167  
B-1410 Waterloo, Belgium  
www.bobcat.com